

Stormwater Pollution Prevention Plan

**Stonemill Estates 2nd Addition
Residential Subdivision
Underground Utility, Street Improvements and Homes**



ENG. NO. 15-A6-3
LEGAL NO. A6-3-2015

Project Location
NE ¼ of Section 29, Township 139N, Range 48W

Prepared By: Andrea J. Crabtree Nayes
August 27, 2015

TABLE OF CONTENTS

1. Stormwater Pollution Prevention Plan (SWPPP)
 - a. Introduction
2. Site Information
 - a. Nature of Activity
 - i. Soil Type
 - ii. Groundwater Data
 - iii. Stormwater Drainage/Name of Receiving Water
 - b. Pre vs Post-construction Impervious Area
 - c. Intended Sequence of Major Construction Activities
 - d. Critical Areas
3. SWPPP Implementation and Chain of Responsibility
 - a. Erosion Control Supervisor and Duties
 - b. Certification of Erosion Control Supervisor
 - c. Regulatory Officials
 - d. Employee Training
4. Description of Controls
 - a. Erosion and Sediment Controls and Stormwater Management
 - b. Stabilization Time Schedule for Soil Exposure
 - c. Identification of Potential Pollutants and Process for Containment
 - i. Significant Materials Inventory
 - d. Potential Locations for Stormwater Contamination
 - e. Additional Pollution Management Controls
 - f. Dewatering Discharges
5. Record Keeping, Inspections and Maintenance Procedures
 - a. Record Retention
 - b. Inspections
 - c. Maintenance
6. Changes to the SWPPP
7. Permanent Erosion Control
8. Certification of Compliance with Federal and State Regulations

ATTACHMENTS:

**US QUAD MAP SHOWING PROJECT LOCATION
PROJECT LOCATION COVER SHEET
EROSION/SEDIMENT CONTROL PLAN SHEETS
SWPPP AMENDMENT LOG
SWPPP INSPECTION LOG
GRADING and STABILIZATION ACTIVITIES LOG**

1. Stormwater Pollution Prevention Plan (SWPPP)

a. Introduction

The SWPPP is a requirement of the National Pollution Discharge Elimination System (NPDES) permit, which is a document that the owner of the site has a pollution control plan in place. The SWPPP shows compliance with the NPDES deadlines and pollution control measures.

The SWPPP including all changes to it, and inspections and maintenance records must be kept at the site during construction. The SWPPP can be kept in either the field office or in an on-site vehicle during normal working hours. Project records must be kept for three (3) years after submittal of the MPCA NOT, see section 6.a Record Retention of this report.

2. Site Information

a. Nature of Activity

The project involves the placement of underground utilities and streets in an existing farm field to service residential development. Because of the placement of storm sewer there is potential for sediment to be discharged from the site. The erosion and sediment control practices are outlined in the plans and SWPPP to prevent and/or capture such discharges. Only areas shown on the plans are to be disturbed.

i. Soil Types

According to the USDA Soil Survey (map below), the soil types in the project area are classified as type C and C/D soils.

Group C – Soils having a slow infiltration rate when thoroughly wet. These consist chiefly of soils having a layer that impedes the downward movement of water or soils of moderately fine texture of fine texture. These soils have a slow rate of water transmission.

Group D – Soils having a very slow infiltration rate (high runoff potential) when thoroughly wet. These consist chiefly of clays that have a high shrink-swell potential, soils that have a high water table, soils that have a claypan or clay layer at or near the surface, and soils that are shallow over nearly impervious material. These soils have a very slow rate of water transmission.

ii. Groundwater Conditions

The water table for the project area varies between 23 cm to >200 cm.

“Water table” refers to a saturated zone in the soil. It occurs during specified months. Estimates of the upper limit are based mainly on observations of the water table selected sites and on evidence of a saturated zone, namely grayish colors in the soil. A saturated zone that lasts for less than a month is not considered a water table.

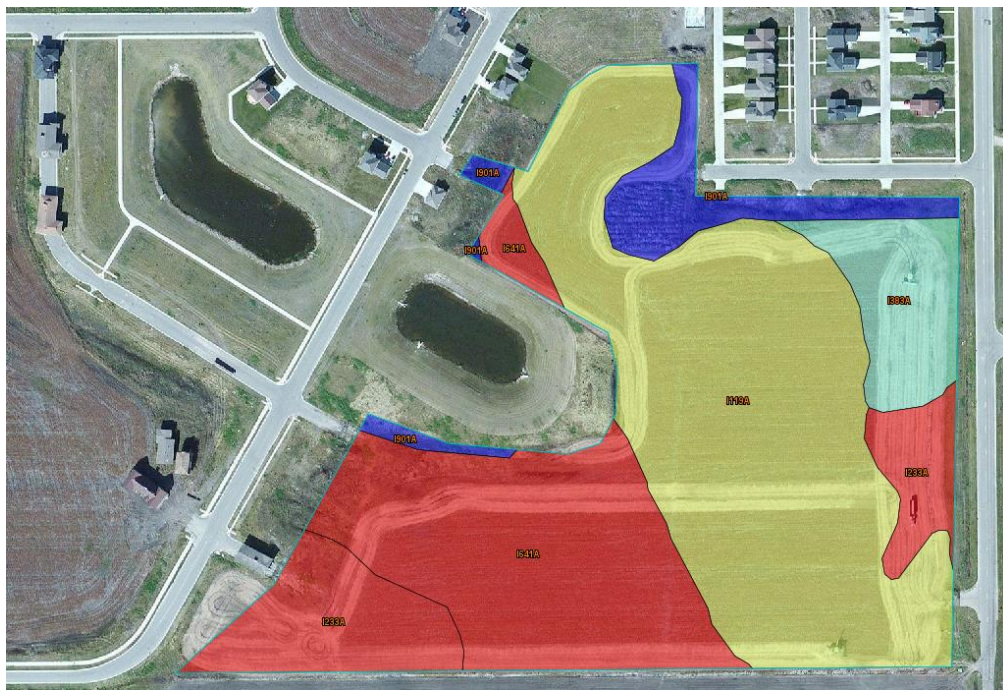

Map #	Soil Name	Soil Group	Water Table	Drainage Class
I119A	Bearden-Fargo complex	C	76 cm	Somewhat poorly drained
I233A	Fargo silty clay loam	C/D	23 cm	Poorly drained
I383A	Overly silty clay loam	C	122 cm	Moderately well drained
I641A	Fargo silty clay, silty substratum	C/D	23 cm	Poorly drained
I901A	Urban land-aquerts complex		>200 cm	

iii. Stormwater Drainage/Name of Receiving Water

Runoff from the project area will flow into storm sewer pipes. The storm sewer pipes will discharge into the southeast regional stormwater pond. From the southeast stormwater pond the water will flow into the northwest stormwater pond and discharge into the drainage ditch before ultimately reaching the Red River of the North. The Red River of the North is listed as impaired water on the 303(d) list. No TMDL study plan has been approved by the EPA at this time. The pollutant/stressor for this portion of the Red River is turbidity.

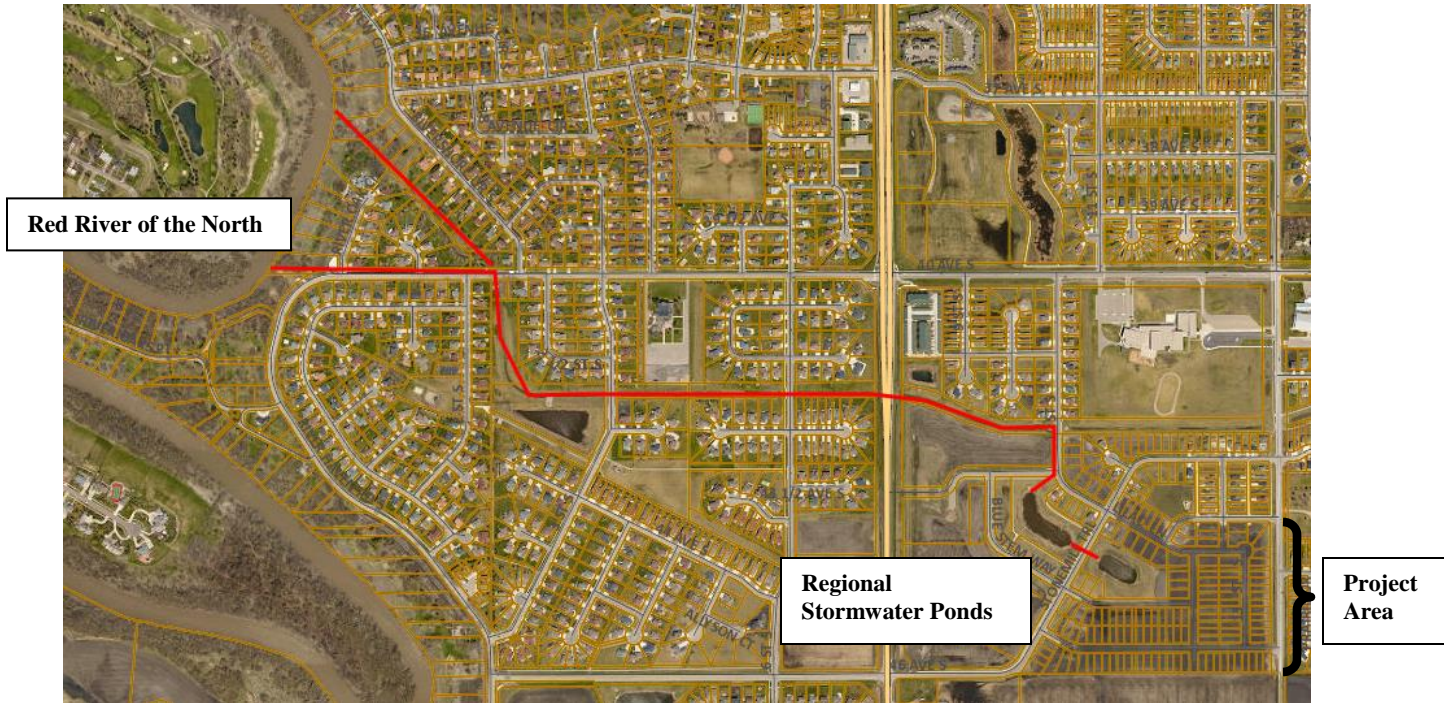

b. Pre vs Post-construction Impervious Area

The subdivision is approximately 30 acres and is broken down into two different projects. The City’s project will consist of underground utilities, streets and trails and disturbed 12.8 acres of land. The Developers portion of the subdivision project will consist of building residential homes and disturb approximately 17 acres of land.

The breakdown of the pre-construction and post-construction surface areas are as follows.

Subdivision Impervious Surface	Acres
Existing Impervious	0.2
New Impervious (Road/Trails) - City	4.9
Residential Homes - Developer	13.4
Total Project Impervious	18.5

c. Intended Sequence of Major Construction Activities

Before any soil disturbing activity may commence, all pre-construction BMPs must be in place. The contractor shall develop or modify the phasing of BMPs.

Phase 1 – Start of construction, no earthwork operations shall begin prior to temporary erosion and sediment control measures being installed that are down gradient from the disturbed construction area.

- Construction entrances/exits – Construction entrance and exit shall be placed on Blue Stem Way and 46th Ave S. (See Erosion and Sediment Control Plan Sheet)
- Inlet protection shall be placed along Stonemill Trail, 45th Ave S and 14th St S (See Erosion and Sediment Control Plan Sheet)
- Strip and stockpile topsoil.

Phase 2 – Placement of utilities

- Install inlet protection during storm sewer construction.

Phase 3 – Stabilization of the boulevards and transferring the MPCA Permit to the Developer.

- Ryan Contracting shall initiate stabilization of the boulevards immediately and in no case later than seven (7) days once construction activity temporary or permanently ceases.
- Ryan Contracting shall leave the BMPs in place for the Developer.
- The MPCA permit will be transferred to the Developer for the home Building Phase of the construction project.

Phase 4 – Home Building Phase;

- If the Developer sells off individual lots than an MPCA permit modification form must be submitted to the MPCA to subdivide the lot from the original MPCA General Stormwater Permit.
- Individual lots are considered to have final stabilization if the structure is finished, the temporary erosion protection and down gradient perimeter control has been completed and the residence has been sold to the homeowner.
- The new Homeowner shall be given the MPCA Homeowner Fact Sheet to inform the homeowner of the need for, and benefits of, permanent cover.

d. Critical Areas

The Contractor shall pay special attention to protecting the storm sewer system. The storm sewer system drains to the existing Stonemill regional stormwater ponds. It is the Contractor's responsibility to make sure that the storm sewer system is protected at all times.

3. Chain of Responsibility

The City of Moorhead applied for the General Stormwater Permit for Construction Activity (MN R100001) and is listed as "Owner". As outlined in the Project Specifications Special Provisions, the "Contractor" is a co-permittee with the City of Moorhead. The Contractor shall be solely responsible for complying with the requirements of Part IV (Construction Activity Requirements) of the General Stormwater Permit where "Permittee", "Owner" or "Operator" is referenced until the Permit has been transferred to the Developer.

- a. The implementation of the SWPPP, and the insulation, inspection and maintenance of the erosion prevention and sediment control BMPs before and during construction activity for the City portion of the project until the MPCA permit is transferred.
 - i. Contractor: Ryan Contracting
 - ii. Site Contact:

- b. The implementation of the SWPPP, and the insulation, inspection and maintenance of the erosion prevention and sediment control BMPs during the home building phase of the project until the MPCA permit is terminated.
 - i. Contractor:
 - ii. Site Contact:



Minnesota Pollution
Control Agency

Coverage Card

Construction Stormwater National Pollutant Discharge Elimination System/State Disposal System General Permit MNR100001

The Construction site identified below is covered under the National Pollutant Discharge Elimination System/State Disposal System General Permit MNR100001 and is authorized by the Minnesota Pollution Control Agency (MPCA) to discharge stormwater associated with construction activities.

Permit ID Number: C00041419
Owner: City of Moorhead
General Contractor: Ryan Contracting
Project Name: Stonemill Estates 2nd Addition (15-A6-3) CSW

Permit Coverage Date: 9/3/2015

If you have questions regarding the stormwater program for construction activity, please access the MPCA Stormwater website at <http://www.pca.state.mn.us/stormwater>, or call the Construction Stormwater Program at 651-757-2119 or toll free at 800-657-3804.

4. SWPPP Implementation

The Contractor shall be responsible for providing all inspections, documentation, record keeping, maintenance, remedial actions, and repaired required by the permit. All inspections, maintenance, and records required in the General Stormwater Permit Paragraph IV.E shall be the sole responsibility of the Contractor.

The Contractor shall have all logs, documentation and inspection reports on-site for the Engineer to review and shall post the MPCA General Stormwater Permit. If there is not a job trailer on-site than the Erosion Control Supervisor shall have the documents available within 72 hours upon request.

- SWPPP Document
- MPCA Construction Stormwater Coverage Card
- SWPPP Amendment Log
- SWPPP Inspection Log
- Grading and Stabilization Activities Log

When the MPCA permit is transferred the above language applies to the Developer.

a. Erosion Control Supervisor and Duties

The Erosion Control (EC) Supervisor will be provided by the Contractor during construction activities and until their responsibilities have been transferred or terminated under the terms of the MPCA permit.

The EC supervisor will oversee the implementation of the SWPPP and the installation, inspection, and maintenance of the erosion prevention and sediment control BMPs before and during construction. It will be the responsibility of the EC Supervisor to enforce the SWPPP during construction and to maintain a quality control program, including providing contingency plans.

1. Coordinate and schedule the work of subcontractors so that erosion and sediment control measures are fully executed for each operation and in a timely manner over the duration of the Contract.
2. Oversee the work of the subcontractors so that appropriate erosion and sediment preventive measures are undertaken at each stage of the work.
3. Inspect or monitor activities related to the SWPPP as needed.
4. Ensure that proper cleanup occurs from vehicle tracking on paved surfaces and/or any location where sediment leaves the Right-of-Way.
5. Identify additional potential sources of pollutants not included in the SWPPP and take appropriate action to add them to the plan.
6. Ensure that any changes made to construction plans are consistent with the goals of the SWPPP.
7. To aid in the implementation of the SWPPP, random site visits will occur by the design team as well as an inspector on-site.

The EC Supervisor will be identified by name at the pre-construction conference, and a contact cell phone number will be made available. If the EC Supervisor is unable to perform the

required duties due to illness, vacation or some other unforeseen event, an EC Supervisor designate shall be responsible for all parts of this document.

b. Certification of Erosion Control Supervisor

The Contractor shall provide a certified Erosion Control (EC) Supervisor to direct the Contractor and subcontractor(s) operations and insure compliance with Federal, State and Local ordinances and regulations. The certification is obtained by completing a two day Erosion/Sediment Control Site Management training class and passing the required test.

The EC Supervisor will provide the City of Moorhead with the following information as required in the MPCA Permit.

- Names of the personnel associated with this project that are required to be trained.
- Dates of training and name of instructor(s) and entity providing training.
- Content of training course or workshop (including number of hours of training)

c. Regulatory Officials

The EC Supervisor will address issues that impact the “waters of the State” of Minnesota arising during construction. The Supervisor will notify the proper regulatory officials as listed below:

<u>Agency</u>	<u>Permit</u>	<u>Name</u>	<u>Phone #</u>
State Duty Officer	MPCA		800-422-0798
MPCA Detroit Lakes	MPCA		218-847-1519
City of Moorhead Engineering		Tom Trowbridge	218-299-5390
City of Moorhead Stormwater		Andrea Crabtree Nayes	218-299-5387

Erosion and Stormwater Management

The bearer of this card has been tested and is certified in the area(s) shown on the reverse of this card. Certification expiration dates appear after each certification area.

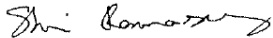

Shri Ramaswamy, Head
Department of Bioproducts and Biosystems Engineering
University of Minnesota

<http://www.erosion.umn.edu>

Card Issued: 6/1/2015

UNIVERSITY OF MINNESOTA

Andrea Crabtree-Nayes

Design of Construction SWPPP (May 31 2018)

In the event of a reportable release the EC Supervisor shall:

- Notify the appropriate regulatory official immediately; and
- Notify permitting authority in writing within 14 days; and
- Modify the SWPPP to include the date of the release, circumstances leading to the release, and steps taken to prevent reoccurrence of the release.

d. Employee Training

The EC Supervisor shall implement and oversee an employee training program to educate the prime contractor's and subcontractors' employees about the requirements of the SWPPP. The education program will include background on the components and goals of the SWPPP and hands-on training in erosion controls, spill prevention and response, good housekeeping, proper material handling, disposal and control of waste, equipment fueling, and inspection procedures. All employees will be training prior to their first day on the site.

5. **Description of Controls**

a. Erosion and Sediment Controls and Stormwater Management

No earthwork operations shall be allowed to begin prior to all temporary erosion and sediment control measures being installed that are down gradient from the disturbed construction area. These practices shall remain in place until final stabilization has been established in accordance with the MPCA General Stormwater Permit for Construction Activities.

Temporary Erosion and Sediment Control measures during Underground and Street paving Phases

Prior to the start of construction the Contractor shall install the following BMPs.

1. Construction entrances/exits must be provided at all locations where construction vehicles enter and exit the site. Construction entrances shall be maintained as necessary to minimize tracking of clay and dirt material off site.
2. Inlet protection must be placed in all existing inlets that will receive runoff from construction site.

During construction activities the Contractor shall;

1. Keep excavations and other soil disturbing activities to practical minimums. Natural vegetation shall be preserved where ever possible.
2. Exposed slopes must be left rough, not smooth, until permanent stabilization is implemented.
3. All equipment and vehicles leaving the construction site shall be cleaned of loose debris and soil.
4. Daily removal of tracked sediments is required on paved streets adjacent to the project areas. **Tracking must be removed by the end of the working day. Large chunks shall be removed immediately.**
5. Haul Routes shall be swept at least once per week while actively grading the project area and/or hauling materials from the project area.
6. Temporary stockpiles are not to be placed in the stormwater conveyance and surface waters. The stockpiles shall be surrounded by appropriate BMPs, and stabilized.
7. Concrete and other washout waste shall not be discharged to "waters of the State", storm sewer system, or allowed to drain onto adjacent properties. Designated washout areas shall be designated and constructed to MPCA standards.
 - All liquid and solid wastes generated by concrete washout operations must be contained in a leak-proof containment facility.

- The liquid and solid wastes must not contact the ground, and there must not be runoff from the concrete washout operations or areas. Liquid and solid wastes must be disposed of properly and in compliance with MPCA regulations.
 - A sign must be installed adjacent to each washout facility to inform concrete equipment operators to utilize the proper facilities.
8. As is appropriate during construction approved inlet protection will be installed on storm sewer inlets. Inlet protection will remain in place until all sources of sediment are permanently stabilized.
 9. Winter stabilization – snowmelt is considered stormwater runoff and is required to be treated.
 - Temporary mulch exposed soil to prevent sediment from leaving site during runoff events.
 - Remove inlet protection by November 1st and reinstall before work commences in spring or no later than April 1st.
 - Move sediment control logs back 2 feet and mark them with an orange 4 foot stake to help prevent City plows from catching and destroying the log.

Best Management Practices Quantity Table (City)

BMPs	Quantity
Rock Construction Entrance	3 EA
Seeding & Type 5 Hydromulch	8.5 ACRE
Inlet Protection	56 EA
Silt Fence	3,170 LF
Sediment Control Log	1,370 LF

Temporary Erosion and Sediment Control during Residential Construction Phase

During the residential building phase the Developer and Lot Owner/Contractor have the responsibility to maintain any erosion and sediment control measure put in place during the previous phases. In addition they must comply with the Residential Erosion Control Standards and the MPCA General Stormwater Permit for Construction Activity (MN R100001).

1. Any erosion control devices damaged during construction must be repaired and replaced within 24 hours of discovery or when site conditions allow access.
2. Each building site must have a designated construction entrance.
3. Tracked sediment must be removed from paved streets by the end of a days work.
4. If dewatering is necessary use a BMP such as a filter bag, sock or a temporary sediment basin.
5. Concrete, paint and other washout waste shall not be discharged to “waters of the State”, storm sewer system, or allowed to drain onto adjacent properties. Designated washout areas shall be constructed to MPCA standards.
 - All liquid and solid wastes generated by concrete washout operations must be contained in a leak-proof containment facility.

- The liquid and solid wastes must not contact the ground, and there must not be runoff from the concrete washout operations or areas. Liquid and solid wastes must be disposed of properly and in compliance with MPCA regulations.
- 6. Weekly site inspections of BMPs must be performed and documented. The City of Moorhead and the MPCA also require that a site inspection be conducted within 24 hours of a rain event of 0.5 inches or greater.
- 7. The permit holder is responsible for erosion control devices year round until the permit is closed. See Residential Standards for winter stabilization.
- 8. Permits
The lot owner and/or contractor must complete and submit the following permits.
 - City of Moorhead Residential Erosion/Sediment Control Permit
 - Submit the City of Moorhead Erosion/Sediment Control Permit to building codes located in City Hall 4th floor when applying for your building permit.
 - If home construction is done by Contractor's that are not the developer than a Minnesota Pollution Control Agency (MPCA) Notice of Termination/Permit Modification (Subdivision Permit) must be submitted to the MPCA.
 - The signed MPCA Notice of Termination/Permit Modification form must be submitted to the MPCA, only submit the SUB00 number to the City on your Erosion/Sediment Control Permit form.

The permits are located on the City of Moorhead's website at www.cityofmoorhead.com.

b. Stabilization Time Schedule for Soil Exposure Condition

City Project - Disturbed soil must be stabilized within seven (7) days once construction activities have ceased. The construction area is within one (1) mile of an impaired water.

Temporary stockpiles without significant silt, clay or organic components (e.g., clean aggregate stockpiles) and the constructed base components of a road are exempt from this requirement but must comply with Part IV.C.5 of the MPCA General Stormwater Permit for Construction Activity (MN R100001).

Developer Phase of the Project – Individual lots are considered finally stabilized if the structure(s) are finished and temporary erosion protection and down gradient perimeter control has been completed and the residence has been sold to the homeowner. Additionally, the seller will distribute the MPCA's Homeowner Fact Sheet to the homeowner to inform the homeowner of the need for, and benefits of, permanent cover.

c. Identification of Potential Pollutants and Process for Containment

The purpose of this section is to identify pollutants that could impact stormwater during and after construction of this project.

Significant Materials Inventory

Pollutants that result from grading and excavation have the potential to be present in stormwater runoff are listed in the following table. The table includes information regarding

material type, chemical and physical description and specific regulated stormwater pollutants associated with each material.

SIGNIFICANT MATERIALS INVENTORY				
Material/Chemical	Physical Description	Stormwater Pollutants	Location	Process for Containment
Pesticides (insecticides, fungicides, herbicides, rodenticides)	Various colored to colorless liquids, powders, pellets or grains	Chlorinated hydrocarbons, organophosphates, carbamates and arsenic	Herbicides used for noxious weed control	Certified applicator
Permanent Seeding Fertilizer	Liquid or solid grains, nitrogen and phosphorus	Nitrogen, phosphorus, organic substrate	Permanent cover - newly seeded areas	Organic base, slow release forms only, tied up in compost
Temporary Seeding Fertilizer	Liquid or solid grains, nitrogen and phosphorus	Nitrogen, phosphorus, organic substrate	Rapid stabilization areas, topsoil berms, stockpiles	Managed application, certified installers, quick cover plant materials
Cleaning Solvents	Colorless, blue or yellow-green liquid	Perchloroethylene, methylene chloride, trichloroethylene, petroleum distillates	No equipment cleaning allowed in project limits	Tarps, monitor weather for rain and wind
Wastewater from construction	Equipment washing rinse water	Water soil, oil, grease and solids	Equipment washing not allowed in project limits	N/A
Concrete	White solid	Limestone, sand	Railroad tracks, culverts, curb and gutter, driveways, home foundations, masonry	Designated wash areas or complete haul removal
Glue, adhesives	White or yellow liquid	Polymers, epoxies	Expansion joints, home construction	Empty container management
Curing compounds	Creamy white liquid	Naphtha	Curb and gutter	Follow manufacturers recommendations
Wood preservatives	Clear amber or dark brown liquids	Stoddard solvent, petroleum distillates, arsenic, copper, chromium	Timber pads, railroad tracks, home construction	Oil absorbing diapers, trained personnel
Hydraulic oil/fluids	Brown oily petroleum hydrocarbon	Mineral oil	Random leaks broken hoses	Oil absorbing diapers, trained personnel
Gasoline	Colorless pale brown or pink liquids	Petroleum hydrocarbon, benzene, ethyl benzene, toluene, xylene, MTBE	Secondary containment	Oil absorbing diapers, trained personnel
Diesel fuel	Clear blue-green to yellow liquids	Petroleum distillates, oil & grease, naphthalene, xylene	Secondary containment	Oil absorbing diapers, trained personnel
Anti-freeze/coolant	Clear green/yellow liquids	Ethylene glycol, propylene glycol	Random leaks and broken hoses	Trained personnel
Soil erosion	Solid particles	Soil, sediment	Project limits	Prevention and Stabilization measures within prescribed periods

d. Potential Locations for Stormwater Contamination

The following areas were identified as potential locations to convey stormwater contamination:

- Storm System Inlets
- Stormwater pond

e. Additional Pollution Management Controls

The EC Supervisor shall implement any process for containment necessary to minimize pollutants, which may include controls not listed below.

- All nonhazardous waste materials will be collected and stored in a securely lidded metal dumpsters or other approved containment method at the end of each day. Any alternative to a metal dumpster will be made and submitted in writing for approval by the Project Engineer.
- All trash and construction debris from the site will be deposited in the dumpster. The dumpster will be emptied as necessary to function as intended for debris collection. No construction materials will be buried on-site. All personnel will be instructed by the contractor's EC Supervisor regarding the correct procedure for all waste disposals.
- Hazardous materials will be limited to gasoline, diesel fuel, and motor oil. The Contractor must make the necessary arrangements to store these hazardous materials in a manner that is compliant with the MPCA regulations. Spills must be reported to the State Duty Officer at 1-800-422-0798.
- External washing of trucks and other construction vehicles will NOT be allowed on the project site. Concrete trucks shall be washed only in designated areas.
- All sanitary waste will be collected from the portable units at rate necessary to maintain designed function, by the licensed sanitary waste management contractor.
- Good housekeeping and spill control practices will be followed during construction to minimize stormwater contamination from petroleum products, fertilizers, paints, and concrete.

To prevent stormwater contamination from occurring, the following BMPs will be implemented. All work, devices, materials and remedial actions required to perform the following tasks as listed below are incidental on the project.

- All vehicles on site will be monitored for leaks and receive regular preventive maintenance to reduce the chance of leakage.
- Petroleum products will be stored in tightly sealed containers which are clearly labeled.
- Spill kits will be included with all fueling sources, maintenance activities, and all construction activities near a "water of the state". Secondary containment measures will be installed and maintained by the contractor.
- Any asphalt substances used onsite will be applied according to the manufacturer's recommendation.
- All paint containers will be tightly sealed and stored when not required for use. Excess paint will not be discharged to the storm sewer system, but will be properly disposed of according to manufacturer's recommendation.
- All spills will be cleaned up immediately upon discovery. Spills large enough to reach the storm sewer system will be reported to the MPCA State Duty Officer (651-649-5451) and should immediately call the City of Moorhead Fire Department dispatch (701-451-7660).
- A stabilized construction entrance/exit will be constructed to reduce vehicle tracking of sediments off project right-of-way.
- A pickup style broom will be required for all street sweeping and project cleanup operations from hard surfaces. An open air broom will be allowed only when the

material is wet due to a rain event, provided the material cannot leave the site from the operation.

f. Dewatering Discharges

The installation of underground utilities may require dewatering at various areas throughout construction. Turbid or sediment filled discharges shall be discharged through a sediment bag or other appropriate BMP in a manner that does not cause a nuisance condition or erosion in receiving channels.

6. Record Keeping, Inspections and Maintenance Procedures

a. Record Retention

Once the City's portion of the project is completed the Contractor shall provide the City of Moorhead with the amended SWPPP. Construction logs shall be submitted with pay requests and will be kept in the project file.

b. Inspections

Erosion prevention and sedimentation control BMPs implemented on this project must be inspected to ensure integrity and effectiveness. Non-functional BMPs must be repaired, replaced or supplemented with functional BMPs.

The EC Supervisor shall maintain records of construction activities, including:

- Visual inspection of all cleared, graded or areas of exposed sub-grade within the project site will be performed daily. Inspections will also be performed within 24 hours after a rainfall event greater than 0.5 inches. Date and time of inspection.
- Formal written inspections will be performed weekly in accordance with the NPDES permit. ***Copies of the written weekly inspections must be submitted along with the monthly pay request. No payments will be made without submitting copies of the inspection records.***
- Name of person conducting inspection.
- Findings of inspections, including the specific location where corrective actions are needed.
- Corrective actions taken (including dates, times and party completing maintenance activity).
- Date and amount of all rainfall amounts greater than 0.5 inches in 24 hours. Rainfall amounts must be obtained by a properly maintained rain gauge installed onsite, a weather station that is within 1 mile of your location or a weather reporting system that provides site specific rainfall data from radar summaries.
- If any discharge is observed to be occurring during the inspection, a record of all points of the property from which there is discharge must be made, and the discharge should be described (i.e., color, odor, floating, settled, or suspended solids, foam, oil sheen, and other obvious indicators of pollutants) and photographed.
- Amendments to the SWPPP must be documented within seven (7) days. If construction activities or design modifications are made to the site plan, which could impact stormwater, this SWPPP will be amended appropriately. The amended

SWPPP will have a description of the new activities that contribute to the increased pollutant loading and the planned source control measures.

- Inspection frequency adjustment
 1. Where parts of the project site have permanent cover, but work remains on other parts of the site, the Permittee may reduce inspection of the areas with permanent cover to once per month.
 2. Where construction sites have permanent cover on all exposed soil areas and no construction activity is occurring anywhere on site, the site must be inspected during non-frozen ground conditions at least once per month for a period of twelve (12) months. Following the twelfth month of permanent cover and no construction activity, inspections may be terminated until construction activity is once again initiated unless the Permittee is/are notified in writing by the MPCA that erosion issues have been detected at the site and inspections need to resume.
 3. Where work has been suspended due to frozen ground conditions, the inspections may be suspended. The required inspections and maintenance schedule must begin within 24 hours after runoff occurs at the site or 24 hours prior to resuming construction, whichever comes first.

c. Maintenance

The Contractor is responsible for maintaining all BMPs during construction, as outlined in this SWPPP as well as within the project plans & specifications and meeting the requirements of the NPDES permit.

- All perimeter control devices must be repaired, replaced, or supplemented when they become nonfunctional or sediment reaches $\frac{1}{2}$ the height of the device. These repairs must be made by the end of the next business day after discovery, or thereafter as soon as field conditions allow access.
- Concrete washouts shall be cleaned by the contractor when they reach 80% of their capacity. All material removed shall be the responsibility of the contractor and disposed of properly.
- Temporary sediment basins must be drained and the sediment removed when the depth of the sediment collected in the basin reaches $\frac{1}{2}$ the storage volume. Drainage and removal must be completed within 72 hours of discovery, or as soon as field conditions allow access.
- Surface waters, including drainage ditches and conveyance systems, must be inspected for evidence of erosion and sediment deposition during each inspection. The Contractor must remove all deltas and sediment deposited in surface waters and re-stabilizes the areas where sediment removal resulted in exposed soil. The removal and stabilization must take place within seven (7) days of discovery, unless precluded by legal, regulatory, or physical access constraints. The Contractor shall use all responsible efforts to obtain access. The Contractor is responsible for contacting all local, regional, state and federal authorities and receiving any applicable permits, prior to conducting any work in surface waters.

- Construction site entrances/exits must be inspected for evidence of off-site sediment tracking onto paved surfaces. Tracked sediment must be removed from all paved surfaces by the end of working day.

7. Changes to the SWPPP

The EC Supervisor shall immediately initiate any changes required to this SWPPP, the construction documents, or construction diaries, when:

- Notified by the MPCA, EPA, or other regulatory authority that the SWPPP does not comply.
- Changed in design, construction staging, construction operations, or maintenance which has an effect on the potential for discharge of pollutants.
- Any amendments to the SWPPP proposed as a result of the inspection must be documented within seven (7) calendar days.
- If there is a reportable release of a pollutant.

8. Permanent Erosion Control

The EC Supervisor shall ensure temporary pollution prevention controls remain in place until;

- All sediment must be removed from the storm sewer system.
- Turf establishment by seeding with 25-151 seed mixture and hydraulic matrix type 5 mulch shall be completed in accordance with MnDOT 2575.
- The Contractor shall leave the inlet protection in place for the Developer.
- Remove all other temporary synthetic and structural erosion prevention and sediment control BMPs.
- The City will transfer the MPCA permit to the Developer.

The individual lots are considered stabilized if the structure(s) are finished and temporary erosion protection and down gradient perimeter control has been completed and the residence has been sold to the homeowner. Additionally, the seller will distribute the MPCA's Homeowner Fact Sheet to the homeowner to inform the homeowner of the need for, and benefits of, permanent cover.

The final permanent erosion control will consist of turf lawns by the homeowner(s).

9. Certification of Compliance with Federal and State Regulations

This SWPPP reflects the requirements of NPDES for stormwater management and erosion and sediment control for construction. To ensure compliance, this plan was prepared in accordance with the University of Minnesota Design Training Certification Program, MnDOT specifications used in the project plans and specifications and the Memorandum of Understanding between MnDOT and MPCA.

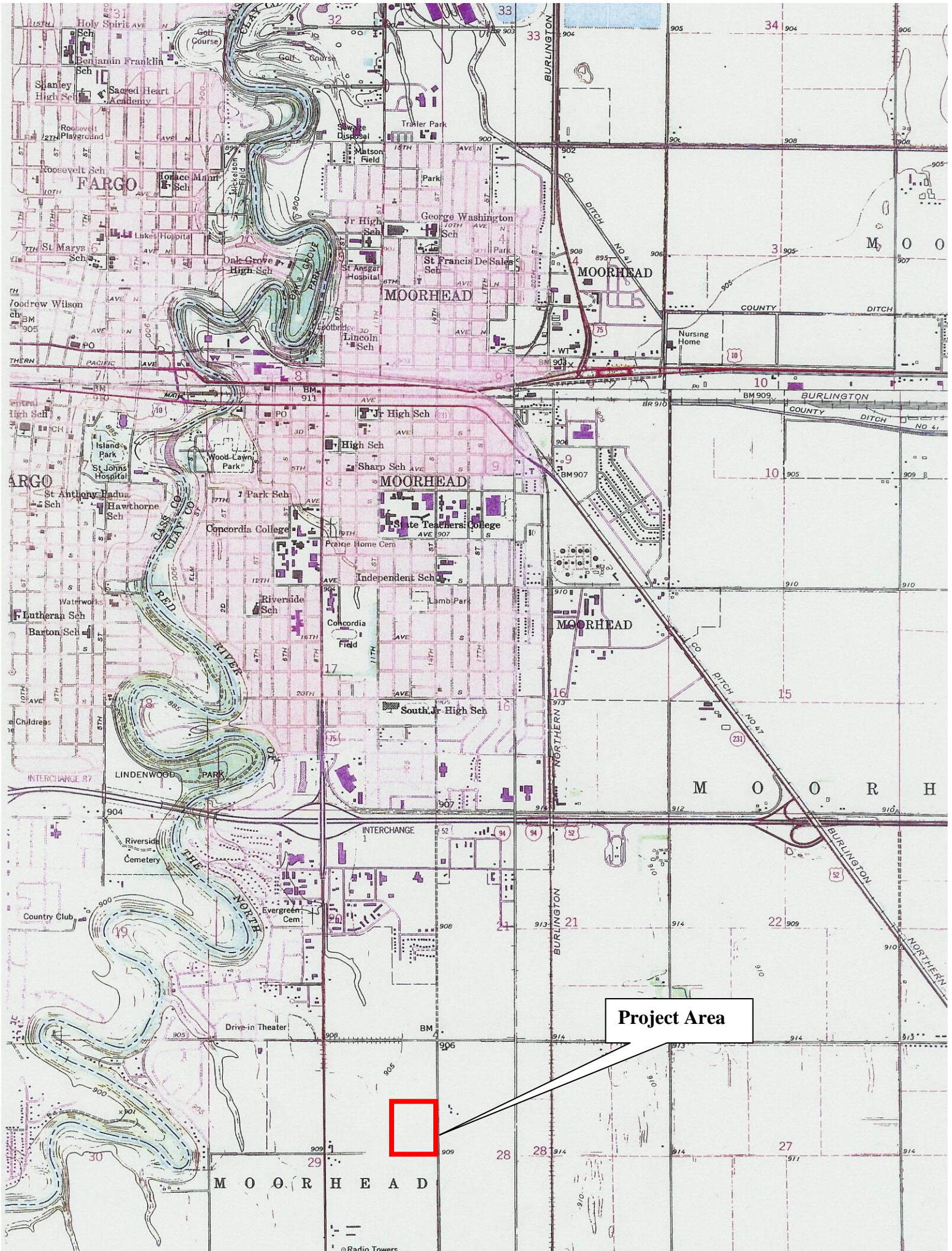

Project Area



CONSTRUCTION PLANS FOR STONEMILL ESTATES 2ND ADDITION

UNDERGROUND UTILITIES & STREET IMPROVEMENTS

MOORHEAD, MINNESOTA 2015

CITY ENG NO. 15-A6-3
LEGAL NO. A6-3-2015



GOVERNING SPECIFICATIONS

THE 2014 EDITION OF THE MINNESOTA DEPARTMENT OF TRANSPORTATION "STANDARDS SPECIFICATIONS FOR CONSTRUCTION" ALONG WITH THE CITY OF MOORHEAD STANDARD SPECIFICATIONS AND THE SPECIAL PROVISIONS SHALL GOVERN.

ALL TRAFFIC CONTROL DEVICES SHALL CONFORM TO THE MN MUTCD MANUAL DATED JANUARY 2014, AND TEMPORARY TRAFFIC CONTROL ZONE LAYOUTS (FIELD MANUAL) DATED JANUARY 2014.

INDEX OF DRAWINGS

SHEET NO.	DESCRIPTION
1	COVER
2	OVERALL LAYOUT
3	QUANTITIES
4-6	EROSION CONTROL
7-8	REMOVALS
9	PIPE & STRUCTURE SCHEDULE - SS
10	PIPE & STRUCTURE SCHEDULE - STS
11-12	UTILITY PLAN & PROFILE - 46 AVE S.
13	UTILITY PLAN & PROFILE - BLUE STEM WAY
14-15	UTILITY PLAN & PROFILE - LILAC LANE
16	UTILITY PLAN & PROFILE - 45 AVE S.
17	UTILITY PLAN & PROFILE - 12 ST S.
18-19	UTILITY PLAN & PROFILE - 13 ST S.
20	UTILITY PLAN & PROFILE - EAST INLET
21	UTILITY PLAN & PROFILE - BACKYARD BLOCK 4
22	UTILITY PLAN & PROFILE - WEST INLET
23	UTILITY PLAN & PROFILE - BACKYARD BLOCK 5
24	UTILITY PLAN & PROFILE - BACKYARD BLOCK 6
25	UTILITY PLAN & PROFILE - BACKYARD BLOCK 7
26	UTILITY PLAN & PROFILE - BACKYARD BLOCK 8
27-28	UTILITY PLAN & PROFILE - 14 ST S.
29	ELECTRICAL CONDUIT
30	TYPICAL SECTION
31-32	PAVING PLAN & PROFILE - 46 AVE S.
33	PAVING PLAN & PROFILE - BLUE STEM WAY
34-35	PAVING PLAN & PROFILE - LILAC LANE
36	PAVING PLAN & PROFILE - 45 AVE S.
37	PAVING PLAN & PROFILE - 12 ST S.
38-39	PAVING PLAN & PROFILE - 13 ST S.
40-44	ADA RAMP DETAILS
45	LOT GRADING
46-50	SIGNING & PAVEMENT MARKING
51-52	DETAILS - WATERMAIN
53-54	DETAILS - SANITARY SEWER
55-56	DETAILS - STORM SEWER
57	DETAILS - EROSION CONTROL
58-60	CROSS SECTIONS - 46 AVE S.
61-62	CROSS SECTIONS - BLUE STEM WAY
63-64	CROSS SECTIONS - LILAC LANE
65	CROSS SECTIONS - 45 AVE S.
66-67	CROSS SECTIONS - 12 ST S.
68-70	CROSS SECTIONS - 13 ST S.

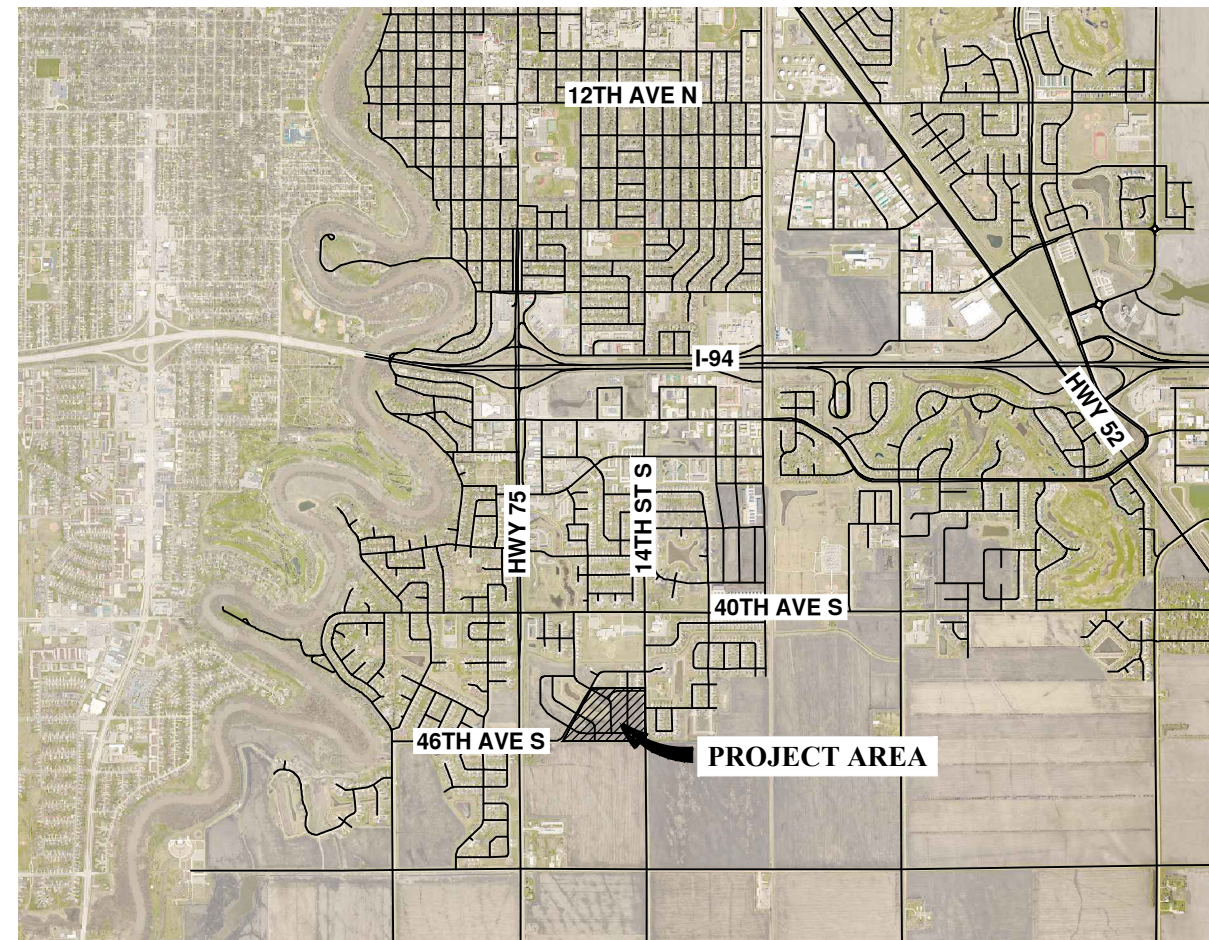

I hereby certify that this plan, specification, or report was prepared by me or under my direct supervision, and that I am a duly Licensed Professional Engineer under the laws of the State of Minnesota.

Michael P. Love /s/

Michael P. Love
License No. 45726

Date: 8/6/15

I hereby certify that this plan, specification, or report was prepared by me or under my direct supervision, and that I am a duly Licensed Professional Engineer under the laws of the State of Minnesota.

Jeffrey T. Lansink /s/

Jeffrey T. Lansink
License No. 44790

Date: 8/6/15

THE UNDERGROUND UTILITIES HAVE BEEN LOCATED FROM FIELD SURVEY INFORMATION, AS-BUILT MAPS AS PROVIDED BY MUNICIPALITIES OR UTILITY COMPANIES, AND/OR EXISTING DRAWINGS. THERE IS NO GUARANTEE THAT THE UNDERGROUND UTILITIES SHOWN COMPRISE ALL SUCH UTILITIES IN THE AREA, EITHER IN SERVICE OR ABANDONED. NOR IS THERE A GUARANTEE THAT THE UNDERGROUND UTILITIES SHOWN ARE IN THE EXACT LOCATION INDICATED. THE CONTRACTOR SHALL DETERMINE THE EXACT LOCATION OF ANY AND ALL EXISTING UTILITIES. THE CONTRACTOR AGREES TO BE FULLY RESPONSIBLE FOR ANY AND ALL DAMAGES WHICH MAY RESULT FROM HIS FAILURE TO LOCATE AND PRESERVE ANY AND ALL UTILITIES.

H:\Fargo\JBN\6000\60019\15_0019_071\CAD\Plans\COVER.dwg COVER-8/6/2015 3:42 PM (jrburd)

	Fargo
	P: 701.237.5065 F: 701.237.5101

H:\Fargo\JBN6000\6019\15_6019_071\CAD\Plans\OVERALL.dwg-Overall (3)-8/6/2015 3:43 PM (trud)

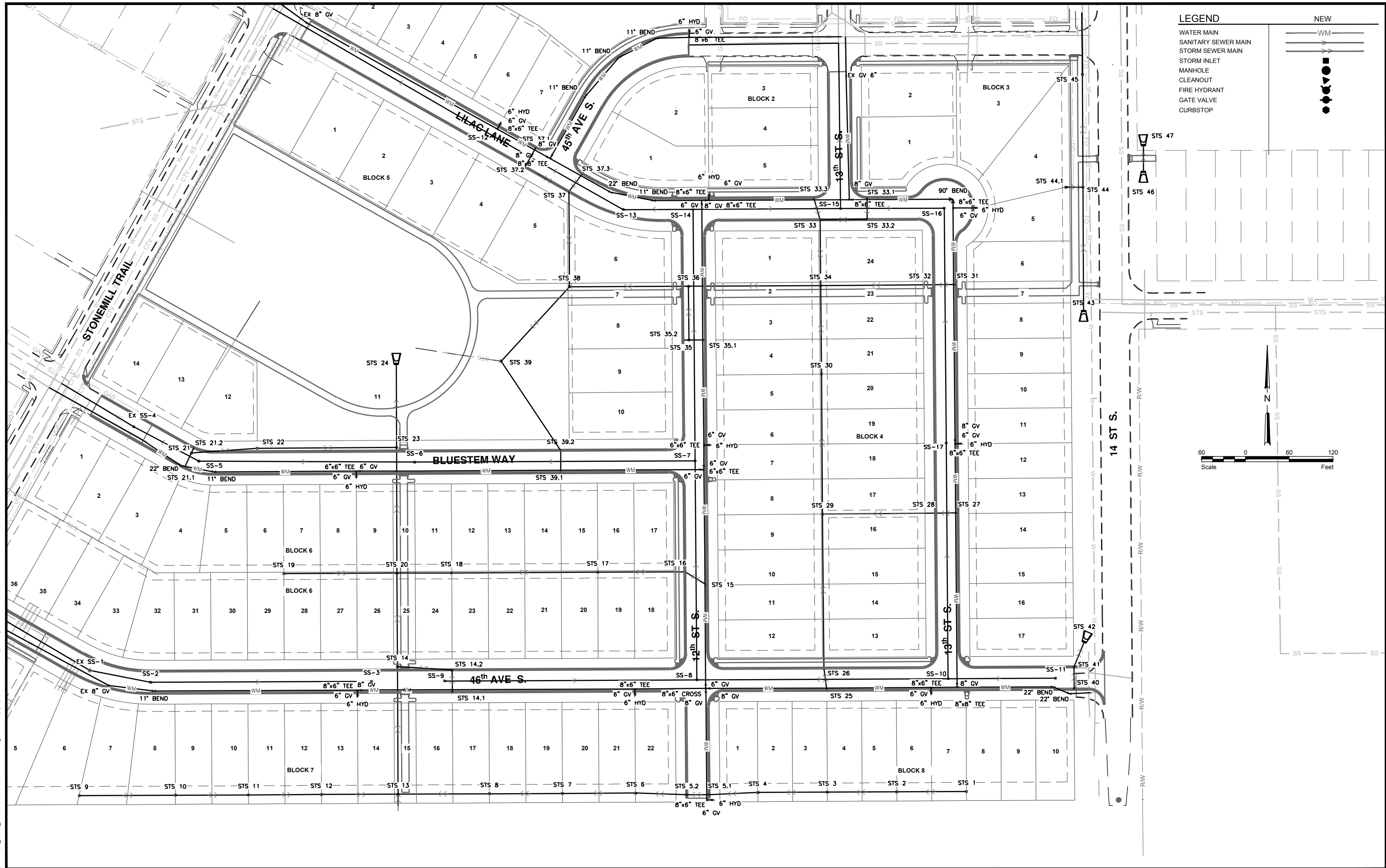

No.	Revision	Date	By

This document was originally signed by Jeffrey T. Lansink, License No. 44790, on 8/06/2015 and the original document is stored at Houston Engineering Inc.



Fargo
P: 701.237.5065
F: 701.237.5101

Drawn by AMR
Checked by JTL
Date 8/6/15
Scale AS SHOWN

STONEMILL ESTATES
2ND ADDITION
MOORHEAD, MINNESOTA

OVERALL LAYOUT &
TABLE OF CONTENTS
PROJECT NO. 6019-071

SHEET
2 of 70

QUANTITIES

No.	Item	Spec No.	Unit	Quantity	No.	Item	Spec No.	Unit	Quantity
Watermain					Storm Sewer				
1	REMOVE & SALVAGE HYDRANT	2104.523	EA	1	41	30" RC PIPE SEWER	2503.511	LF	483
2	4" INSULATION	2502.604	SY	90	42	36" RC PIPE SEWER	2503.511	LF	325
3	INSTALL SALVAGED HYDRANT	2504.601	EA	1	43	48" RC PIPE SEWER	2503.511	LF	607
4	6" GATE VALVE AND VALVE BOX	2504.602	EA	16	44	58" x 36" RC PIPE SEWER	2503.511	LF	38
5	8" GATE VALVE AND VALVE BOX	2504.602	EA	9	45	CONNECT TO EXISTING STORM SEWER	2503.602	EA	1
6	11° BEND	2504.602	EA	6	46	INSTALL PLUG	2504.602	EA	1
7	22° BEND	2504.602	EA	4	47	48" STORM SEWER MANHOLE	2506.602	EA	11
8	90° BEND	2504.602	EA	1	48	48" STORM SEWER TEE MANHOLE	2506.602	EA	1
9	6"x6" TEE FITTING	2504.602	EA	3	49	60" STORM SEWER MANHOLE	2506.602	EA	6
10	8"x6" TEE FITTING	2504.602	EA	11	50	72" STORM SEWER MANHOLE	2506.602	EA	1
11	8"x8" TEE FITTING	2504.602	EA	2	51	84" STORM SEWER MANHOLE	2506.602	EA	3
12	8"x6" CROSS	2504.602	EA	1	52	STORM SEWER INLET (DESIGN H)	2506.602	EA	36
13	6" PIPE PLUG	2504.602	EA	1	Street				
14	CONNECT TO EXISTING WATER MAIN	2504.602	EA	6	53	REMOVE CONCRETE DRIVEWAY PAVEMENT	2014.501	SF	855
15	FIRE HYDRANT	2504.602	EA	10	54	REMOVE CURB & GUTTER	2104.501	LF	201
16	6" PVC WATERMAIN	2504.603	LF	1,737	55	REMOVE BITUMINOUS PAVEMENT	2104.503	SF	6,696
17	8" PVC WATERMAIN	2504.603	LF	3,357	56	SAWING BITUMINOUS PAVEMENT	2104.513	LF	265
Services					57	COMMON EXCAVATION (P)	2105.501	CY	4,591
18	REMOVE EXISTING SERVICE	2104.501	LF	171	58	SUBGRADE EXCAVATION (P)	2105.507	CY	6,794
19	SANITARY SEWER SERVICE WYE	2503.602	EA	120	59	GEOTEXTILE FABRIC	2105.604	SY	20,243
20	4" PVC PIPE SEWER	2503.603	LF	4,670	60	SUBGRADE PREPARATION	2112.604	SY	20,243
21	4" PVC PIPE SEWER RISER	2503.603	LF	435	61	AGGREGATE BASE CLASS 5 (MODIFIED)	2211.501	TON	6,370
22	1" CORPORATION STOP	2504.602	EA	120	62	MILL BITUMINOUS SURFACE (2.0")	2232.501	SY	161
23	1" CURB STOP AND BOX	2504.602	EA	122	63	TYPE SP 12.5 WEARING COURSE MIX (2,B)	2360.501	TON	1,832
24	1" TYPE K COPPER PIPE	2504.603	LF	4,610	64	TYPE SP 12.5 NON WEAR COURSE MIX (2,B)	2360.502	TON	3,683
25	SANITARY SEWER SERVICE CLEANOUTS	2506.602	EA	124	65	SIDEWALK	2521.618	SF	40,721
Sanitary Sewer					66	CONCRETE CURB & GUTTER TYPE C	2531.501	LF	9,737
26	REMOVE PVC PIPE	2104.501	LF	39	67	TRUNCATED DOMES	2531.618	SF	527
27	ABANDON PIPE SEWER	2104.525	EA	1	68	6" SOLID LINE WHITE-EPOXY	2582.502	LF	304
28	CONNECT TO EXISTING SANITARY SEWER	2503.602	EA	4	69	4" PERF PVC PIPE DRAIN	2502-541	LF	9,647
29	8" PVC PIPE SEWER	2503.603	LF	4,383	Miscellaneous				
30	48" SANITARY SEWER MANHOLE	2506.602	EA	15	70	MOBILIZATION	2021.501	LS	1
Storm Sewer					71	SALVAGED TOPSOIL (P)	2105.535	CY	20,720
31	REMOVE RC PIPE	2104.501	LF	112	72	1.5" NON-METALLIC CONDUIT	2545.523	LF	540
32	SALVAGE RC PIPE END SECTION	2104.501	EA	1	73	2" NON-METALLIC CONDUIT	2545.523	LF	660
33	REMOVE CB	2104.509	EA	1	74	TRAFFIC CONTROL	2563.901	LS	1
34	58" x 36" RCAP APRON	2501.515	EA	2	75	PERMANENT SIGNING	2564.522	LS	1
35	36" RC PIPE APRON	2501.515	EA	1	76	SILT FENCE, TYPE HI	2573.502	LF	3,170
36	12" RC PIPE APRON	2501.515	EA	1	77	STORM DRAIN INLET PROTECTION	2573.530	EA	56
37	INSTALL SALVAGED 48" RC PIPE APRON	2501.515	EA	1	78	SEDIMENT CONTROL LOG TYPE STRAW	2573.533	LF	1,370
38	12" RC PIPE SEWER	2503.511	LF	858	79	ROCK CONSTRUCTION ENTRANCE	2573.533	EA	3
39	15" RC PIPE SEWER	2503.511	LF	2,818	80	SEEDING	2575.501	ACRE	8.50
40	24" RC PIPE SEWER	2503.511	LF	313					

BASIS OF ESTIMATE:

- HBP (WEARING AND NON WEARING COURSE) - 2 TON/CY
- AGGREGATE BASE COURSE CLASS 5 - 1.875 TON/CY
- TOPSOIL - 12" EXISTING DEPTH

H:\Fargo\JBN\6000\6019\15_6019_071\CAD\Plans\Quantities.dwg:Layout1-8/6/2015 3:43 PM:(arud)

No.	Revision	Date	By	This document was originally signed by Jeffrey T. Lansink, License No. 44790, on 8/06/2015 and the original document is stored at Houston Engineering Inc.		Fargo	Drawn by AMR	Date 8/6/15	STONEMILL ESTATES 2ND ADDITION MOORHEAD, MINNESOTA	QUANTITIES PROJECT NO. 6019-071	SHEET 3 of 70
						P: 701.237.5065 F: 701.237.5101	Checked by JTL	Scale AS SHOWN			

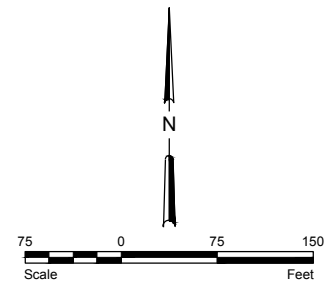

- LEGEND:**
- xx --- SILT FENCE - 3,170 LF
 - --- 12IN BIOROLL - 1,370 LF
 - INLET PROTECTION - 56 EACH
 - ▨ TEMPORARY CONSTRUCTION ENTRANCE - 3 EACH
 - SEEDING/MULCHING 8.50 ACRES

H:\Fargo\JBN\6000\6019\15_6019_071\CAD\Plans\Erosion Control.dwg-SHEET 1-8/6/2015 3:43 PM-(araud)

No.	Revision	Date	By

This document was originally signed by Jeffrey T. Lansink, License No. 44790, on 8/06/2015 and the original document is stored at Houston Engineering Inc.



Fargo
 P: 701.237.5065
 F: 701.237.5101

Drawn by AMR
 Date 8/6/15
 Checked by JTL
 Scale AS SHOWN

**STONEMILL ESTATES
 2ND ADDITION
 MOORHEAD, MINNESOTA**

EROSION CONTROL LAYOUT
 PROJECT NO. 6019-071

SHEET
 4 of 70

STORM WATER POLLUTION PREVENTION PLAN (SWPPP) GENERAL SPECIFICATIONS

THE CONTRACTOR SHALL SUBMIT A NOTICE OF INTENT AND EROSION CONTROL PLAN TO THE OWNER FOR REVIEW 10 DAYS PRIOR TO THE START OF CONSTRUCTION.

THE PURPOSE OF THE SWPPP, OF WHICH THE EROSION CONTROL PLAN IS A PART, IS TO MINIMIZE POLLUTION TO STORM WATERS, IN COMPLIANCE WITH THE NATIONAL POLLUTION DISCHARGE ELIMINATION SYSTEM (NPDES) ENACTED BY THE EPA AND IMPLEMENTED BY THE MPCA.

THE CONTRACTOR AND THE OWNER ARE JOINTLY REQUIRED TO SUBMIT TO THE MN STATE HEALTH DEPT. A NOTICE OF INTENT (NOI) AT LEAST 10 DAYS PRIOR TO COMMENCEMENT OF CONSTRUCTION AT THE SITE.

THE CONTRACTOR IS RESPONSIBLE FOR IMPLEMENTING THE SWPPP AS REQUIRED BY MPCA. THE PLAN PROVIDES STRUCTURAL CONTROLS AND/OR STABILIZATION PRACTICES DESIGNED TO MINIMIZE POLLUTANTS IN THE STORM WATER DISCHARGE (INCLUDING SOIL SEDIMENT), TO MINIMIZE EROSION ON THE SITE, AND TO ELIMINATE TRACKING OF SOIL OFF SITE BY VEHICLES.

A REGULAR PROGRAM OF INSPECTION AND MAINTENANCE OF THE EROSION AND POLLUTION CONTROLS IS REQUIRED BY MPCA. BASED ON THESE INSPECTIONS, THE EROSION AND POLLUTION CONTROLS WILL BE MAINTAINED, MAY BE MODIFIED AND MAY BE SUPPLEMENTED BY ADDITIONAL MEASURES IN ORDER TO ADEQUATELY MINIMIZE POLLUTANTS.

THE CONTRACTOR AND THE OWNER ARE JOINTLY REQUIRED TO SUBMIT TO THE MPCA. A NOTICE OF TERMINATION (NOT) AFTER THE SITE HAS BEEN STABILIZED, CONSTRUCTION HAS ENDED AND TEMPORARY EROSION CONTROL MEASURES HAVE BEEN REMOVED.

STORM WATER MANAGEMENT FEATURES IN ADDITION TO THOSE SHOWN ON THE PLANS SHALL BE PLACED, MONITORED, MAINTAINED, AND REMOVED AT THE DISCRETION AND DIRECTION OF THE OWNER'S REPRESENTATIVE AS NECESSARY.

STRAW BALE CHECKS SHOULD BE INSTALLED AS NEEDED AT SLOPES AND DITCHES. SILT FENCES WILL BE REQUIRED AT THE BOTTOM OF ANY SLOPES SHOWN ON THE PLANS.

SEQUENCE OF CONSTRUCTION

1. INSTALL TEMPORARY CONSTRUCTION ENTRANCES AS REQUIRED.
2. INSTALL PERIMETER SEDIMENT CONTROL DEVICES SUCH AS STRAW BALE CHECKS, SEDIMENT FENCES, ETC. AFTER PREPARING THE INSTALLATION AREA.
3. STRIP SITE OF TOPSOIL AND STOCKPILE
4. EXCAVATE AND CONSTRUCT EMBANKMENTS AS REQUIRED. STOCKPILE EXCESS MATERIAL FOR FUTURE BACKFILL AND EMBANKMENT.
5. MULCH AND SEED DISTURBED AREAS AS SPECIFIED WITHIN 7 DAYS OF TOPSOILING COMPLETION.

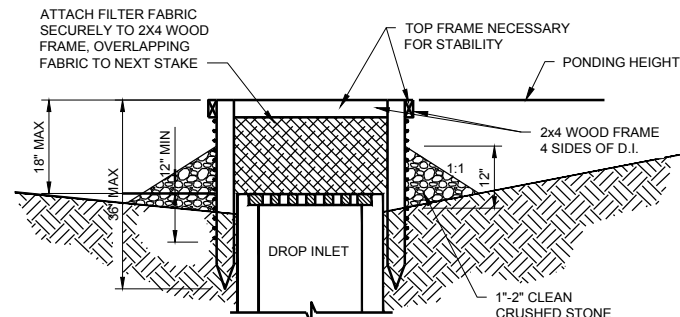
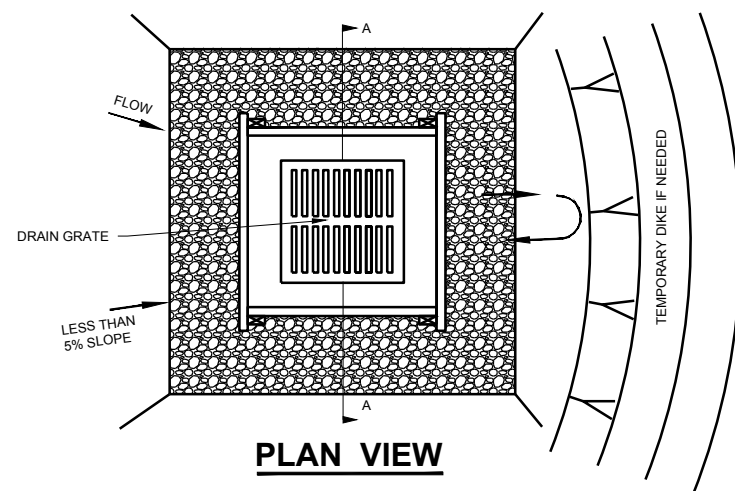

- NOTES:
1. DROP INLET SEDIMENT BARRIERS ARE TO BE USED FOR SMALL, NEARLY LEVEL DRAINAGE AREAS. (LESS THAN 5%)
 2. USE 2X4 WOOD OR EQUIVALENT METAL STAKES, (3 FT. MIN. LENGTH)
 3. INSTALL 2X4 WOOD TOP FRAME TO INSURE STABILITY.
 4. THE TOP OF THE FRAME (PONDING HEIGHT) MUST BE WELL BELOW THE GROUND ELEVATION DOWNSLOPE TO PREVENT RUNOFF FROM BY-PASSING THE INLET. A TEMPORARY DIKE MAY BE NECESSARY ON THE DOWNSLOPE SIDE OF THE STRUCTURE.

INLET PROTECTION - TYPE A
NOT TO SCALE

STORM WATER POLLUTION PREVENTION PLAN REQUIREMENTS

1. THE CONTRACTOR IS RESPONSIBLE FOR OBTAINING A COPY OF AND BEING FAMILIAR WITH THE MPCA. GENERAL PERMIT FOR STORM WATER DISCHARGES ASSOCIATED WITH A CONSTRUCTION SITE.
2. THE CONTRACTOR SHALL PRESERVE THE EXISTING VEGETATION WHERE ATAINABLE. DISTURBED AREAS WILL BE STABILIZED AS SOON AS PRACTICABLE. STABILIZATION PRACTICES MAY INCLUDE: TEMPORARY SEEDING, PERMANENT SEEDING, MULCHING, GEOTEXTILES, SODDING, VEGETATIVE BUFFER STRIPS AND OTHER MEASURES.
3. THE CONTRACTOR SHALL MAINTAIN A RECORD OF THE DATES WHEN MAJOR GRADING ACTIVITIES OCCUR, WHEN CONSTRUCTION ACTIVITIES TEMPORARILY OR PERMANENTLY CEASE ON A PORTION OF THE SITE AND WHEN STABILIZATION MEASURES ARE INITIATED.
4. DISTURBED AREAS WHERE CONSTRUCTION ACTIVITIES HAVE TEMPORARILY OR PERMANENTLY CEASED WILL BE STABILIZED AS SOON AS PRACTICAL BUT IN NO CASE LATER THAN 7 DAYS AFTER CONSTRUCTION ACTIVITY HAS CEASED, UNLESS STABILIZATION IS PRECLUDED BY SNOW COVER.
5. AREAS WHERE CONSTRUCTION ACTIVITY WILL RESUME WITHIN 7 DAYS OF THE TIME CONSTRUCTION ACTIVITY TEMPORARILY CEASES NEED NOT BE STABILIZED.
6. IN ARID AREAS (AVERAGE ANNUAL RAINFALL OF 0 TO 10 INCHES) AND SEMI-ARID AREAS (AVERAGE ANNUAL RAINFALL 10 TO 20 INCHES), STABILIZATION MEASURES SHALL BE INITIATED AS SOON AS PRACTICAL.
7. THE CONTRACTOR SHALL MINIMIZE OFF-SITE TRACKING OF SEDIMENTS AND THE GENERATION OF DUST. GRAVEL CONSTRUCTION ENTRANCE SHALL BE FIELD LOCATED AS NEEDED. IF THE CONTRACTORS OPERATIONS TRACK SEDIMENTS OFF THE SITE ONTO THE EXISTING CITY STREETS, AND AUTHORIZED REPRESENTATIVE OF THE OWNER OR THE CITY OF MOORHEAD MAY REQUEST SWEEPING OF THE STREETS BE PERFORMED. THE CONTRACTOR SHALL PERFORM SWEEPING OPERATIONS WITHIN 24 HOURS OF NOTICE.
8. THE CONTRACTOR SHALL MAINTAIN, REPAIR OR RESTORE ALL GRADE SURFACES, WALLS, DAMS AND STRUCTURES, VEGETATION, EROSION AND SEDIMENT CONTROL MEASURES AND OTHER PROTECTIVE DEVICES IDENTIFIED IN THE SITE PLAN.
9. THE CONTRACTOR SHALL INSPECT ALL EROSION CONTROL PRACTICES ON THE SITE AT LEAST EVERY SEVEN DAYS AND WITHIN 24 HOURS AFTER A STORM EVENT OF 0.5 INCHES OR MORE. THE CONTRACTOR SHALL TAKE ACTION TO ELIMINATE ANY DEFICIENCIES FOUND DURING THESE INSPECTIONS. DOCUMENTATION OF THE INSPECTIONS, THE FINDINGS AND ANY CORRECTIVE ACTIONS SHALL BE MAINTAINED AT THE SITE. THE DOCUMENTATION SHALL INCLUDE A REPORT SUMMARIZING THE SCOPE OF THE INSPECTION(S), NAME(S), AND QUALIFICATIONS OF PERSON MAKING THE INSPECTIONS, THE DATE(S), THE INSPECTIONS, MAJOR OBSERVATIONS RELATED TO THE SWPPP AND ACTIONS TAKEN.

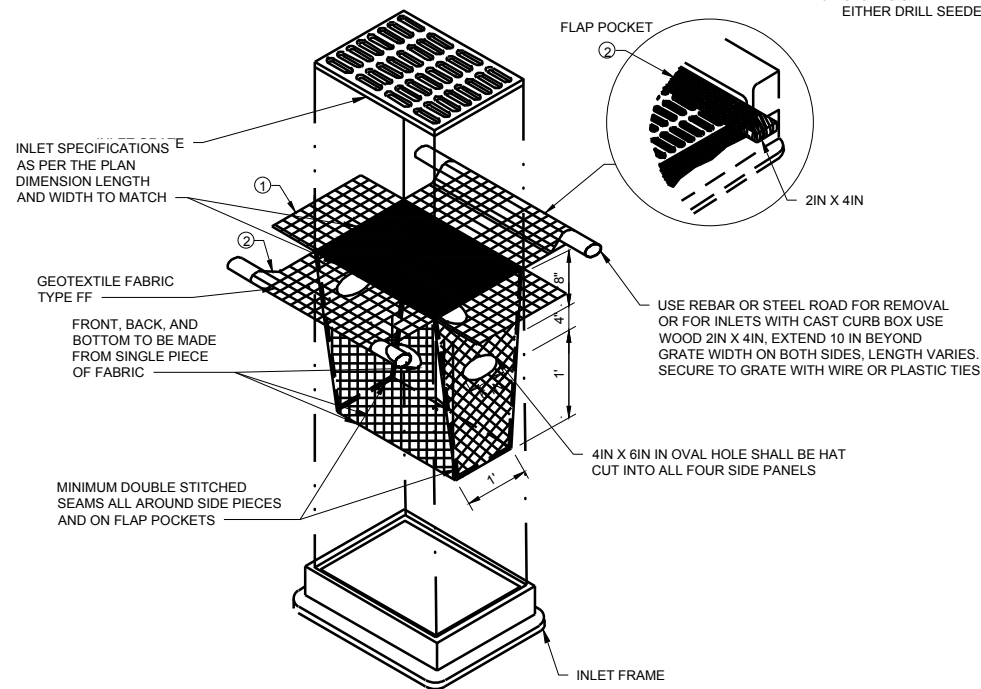

INLET PROTECTION - TYPE B
NOT TO SCALE

- 1 FINISHED SIZE, INCLUDING FLAP POCKETS WHERE REQUIRED, SHALL EXTEND A MINIMUM OF 10 IN AROUND THE PERIMETER TO FACILITATE MAINTENANCE OR REMOVAL.
 - 2 FLAP POCKETS SHALL BE LARGE ENOUGH TO ACCEPT WOOD 2IN X 4IN.
- INSTALLATION NOTES:
- 3 DO NOT INSTALL INLET PROTECTION IN INLETS SHALLOWER THAN 30 IN, MEASURED FROM THE BOTTOM OF THE INLET TO THE TOP OF THE GRATE.
- TRIM EXCESS FABRIC IN THE FLOW LINE TO WITHIN 3 IN OF THE GRATE.

THE INSTALLED BAG SHALL HAVE A MINIMUM SIDE CLEARANCE, BETWEEN THE INLET WALLS AND THE BAG, MEASURED AT THE BOTTOM OF THE OVERFLOW HOLES, OF 3 IN WHERE NECESSARY THE CONTRACTOR SHALL CINCH THE BAG, USING PLASTIC ZIP TIES, TO ACHIEVE THE 3 IN CLEARANCE. THE TIES SHALL BE PLACED AT A MAXIMUM OF 4 IN FROM THE BOTTOM OF THE BAG.

10. WASTE DISPOSAL

THE CONTRACTOR SHALL REMOVE ALL WASTE COMPOSED OF BUILDING MATERIALS FROM THE SITE FOR DISPOSAL IN LICENSED DISPOSAL FACILITIES.

- A. NO BUILDING MATERIAL WASTES OR UNUSED BUILDING MATERIALS SHALL BE BURIED, DUMPED OR DISCHARGED TO WATERS OF THE STATE AT THE SITE.
- B. EACH SITE SHALL HAVE GRAVELED ACCESS ENTRANCE AND EXIT DRIVES AND PARKING AREAS TO REDUCE THE TRACKING OF SEDIMENT ONTO PUBLIC OR PRIVATE ROADS.
- C. ALL UNPAVED ROADS ON THE SITE CARRYING MORE THAN 25 VEHICLES PER DAY SHALL BE GRAVELED.
- D. THE CONTRACTOR SHALL ENSURE AND DEMONSTRATE COMPLIANCE WITH THE APPLICABLE STATE DEPARTMENT OF ENVIRONMENTAL QUALITY OR LOCAL SANITARY SEWER OR SEPTIC SYSTEM REGULATIONS.

11. FUEL AND CHEMICAL STORAGE AREAS

THE CONTRACTOR SHALL PROVIDE CONTAINMENT AROUND FUELING AND CHEMICAL STORAGE AREAS TO ENSURE THAT SPILLS IN THESE AREAS DO NOT REACH WATERS OF THE STATE. CONTINGENCIES SHALL BE PROVIDED FOR THE TREATMENT AND/OR DISPOSAL OF CONTAMINATED SOILS.

12. EXISTING STATE OR LOCAL REQUIREMENTS FOR SEDIMENT AND EROSION CONTROL ARE HEREBY INCORPORATED BY REFERENCE AND ARE ENFORCEABLE.

13. THE CONTRACTOR MUST CLEARLY IDENTIFY FOR EACH MEASURE IDENTIFIED IN THE PLAN. THE CONTRACTOR(S) AND/OR SUBCONTRACTOR(S) THAT WILL IMPLEMENT THE MEASURE. ALL CONTRACTORS AND SUBCONTRACTORS IDENTIFIED BY THE CONTRACTOR MUST SIGN A COPY OF THE CERTIFICATION STATEMENT. ALL CERTIFICATIONS MUST BE INCLUDED IN THE STORM WATER POLLUTION PREVENTION PLAN.

14. CERTIFICATION STATEMENT

ALL CONTRACTORS AND SUBCONTRACTORS SHALL SIGN A COPY OF THE STATE SIGNATORY CERTIFICATION STATEMENT BEFORE CONDUCTING ANY PROFESSIONAL SERVICE AT THE SITE IDENTIFIED IN THE STORM WATER POLLUTION PREVENTION PLAN.

15. THE CERTIFICATION MUST INCLUDE THE NAME AND TITLE OF THE PERSON PROVIDING THE SIGNATURE IN ACCORDANCE WITH THE STATE NPDES PERMIT, THE NAME, ADDRESS AND TELEPHONE NUMBER OF THE CONTRACTING FIRM; THE ADDRESS (OR OTHER IDENTIFYING DESCRIPTION) OF THE SITE; AND THE DATE THE CERTIFICATION IS MADE.

16. SLOPES STEEPER THAN 4:1 SHALL BE HYDROSEEDDED. SLOPES FLATTER THAN 4:1 SHALL BE EITHER DRILL SEEDDED OR HYDROSEEDDED.

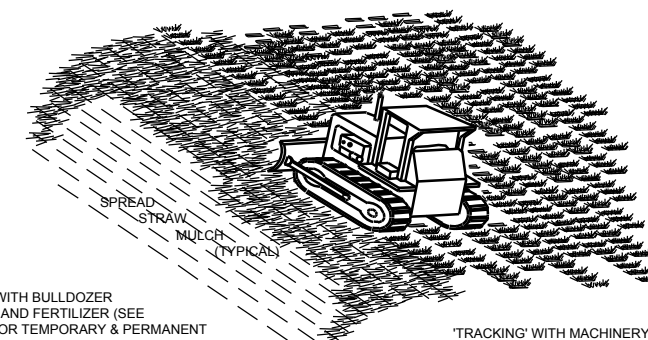

- NOTES:
1. ROUGHEN SLOPE WITH BULLDOZER
 2. BROADCAST SEED AND FERTILIZER (SEE SPECIFICATIONS FOR TEMPORARY & PERMANENT SEED MIXES)
 3. SPREAD STRAW MULCH 2"-2 1/2" THICK (2 TONS PER ACRE)
 4. PUNCH STRAW MULCH INTO SLOPE BY RUNNING BULLDOZER UP AND DOWN SLOPE

STRAW ANCHORING
NOT TO SCALE

H:\Fargo\JBN\6000\6019\15_0019_071\CAD\Plans\Erosion Control.dwg-SHEET 2-8/(/2015 3:43 PM-(araud))

This document was modified by Andrea Crabtree Naves chaged MN Dept of Health to MPCA.		9/3/15	AJCN
No.	Revision	Date	By

This document was originally signed by Jeffrey T. Lansink, License No. 44790, on 8/06/2015 and the original document is stored at Houston Engineering Inc.



Fargo
P: 701.237.5065
F: 701.237.5101

Drawn by AMR
Checked by JTL
Date 8/6/15
Scale AS SHOWN

STONEMILL ESTATES
2ND ADDITION
MOORHEAD, MINNESOTA

EROSION CONTROL DETAILS
PROJECT NO. 6019-071

SHEET
5 of 70

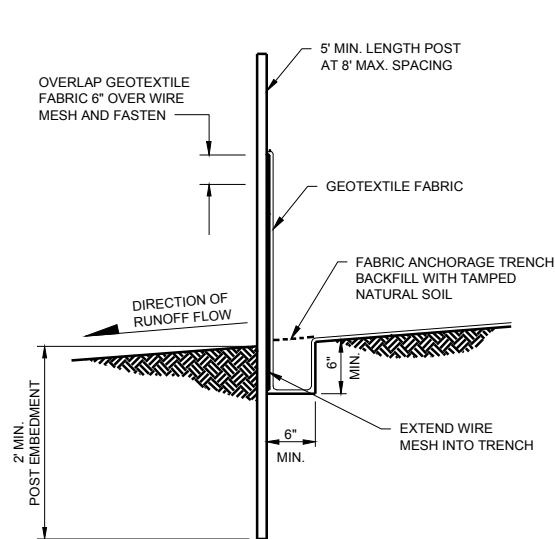

NOTE:
THE GEOTEXTILE FABRIC SHALL MEET OR EXCEED THE FOLLOWING REQUIREMENTS: (FOR FENCE WITH WIRE MESH SUPPORT)

PROPERTY	TEST METHOD	REQUIREMENT
GRAB STRENGTH*	ASTM-D-1682	90 LBS. MIN.
ELONGATION*	ASTM-D-1682	15% MIN. TO 50% MAX. AT 45 LBS.
PERMITTIVITY	ASTM-D-4491	0.01 SEC.
EQUIV. OPENING SIZE	CW02215 (CORPS OF ENG.)	20 TO 80 SIEVE NO.
ULTRAVIOLET RESISTANCE	ASTM-D-4355	70% MIN.
WIDTH		36" MIN.

*12" PER MIN. STRAIN RATE

SILT FENCE
NOT TO SCALE

NOTES:

1. INSPECT AND REPAIR FENCE AFTER EACH STORM EVENT AND REMOVE SEDIMENT WHEN NECESSARY.
2. REMOVED SEDIMENT SHALL BE DEPOSITED TO AN AREA WHERE IT CAN BE PERMANENTLY STABILIZED AND WILL NOT CONTRIBUTE TO SEDIMENT OFF-SITE.
3. SILT FENCE SHALL BE PLACED ON SLOPE CONTOURS TO MAXIMIZE PONDING EFFICIENCY.

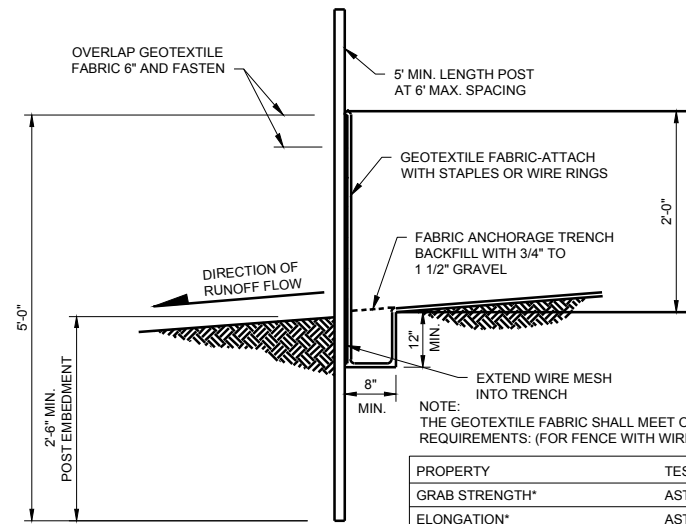
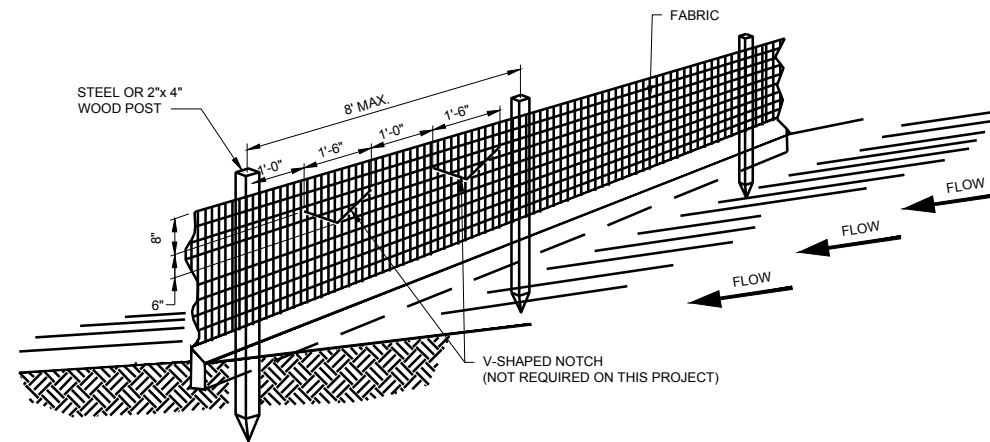

NOTE:
THE GEOTEXTILE FABRIC SHALL MEET OR EXCEED THE FOLLOWING REQUIREMENTS: (FOR FENCE WITH WIRE MESH SUPPORT)

PROPERTY	TEST METHOD	REQUIREMENT
GRAB STRENGTH*	ASTM-D-1682	90 LBS. MIN.
ELONGATION*	ASTM-D-1682	15% MIN. TO 50% MAX. AT 45 POUNDS
PERMITTIVITY	ASTM-D-4491	0.01 SEC.
EQUIV. OPENING SIZE	CW02215 (CORPS OF ENG.)	20 TO 80 SIEVE NO.
ULTRAVIOLET RESISTANCE	ASTM-D-4355	70% MIN.
WIDTH		36 IN. MIN.

* 12" PER MIN. STRAIN RATE

SILT FENCE DETAIL
NOT TO SCALE

NOTES:

1. INSPECT AND REPAIR FENCE AFTER EACH STORM EVENT AND REMOVE SEDIMENT WHEN NECESSARY.
2. REMOVED SEDIMENT SHALL BE DEPOSITED TO AN AREA THAT WILL NOT CONTRIBUTE SEDIMENT OFF-SITE AND CAN BE PERMANENTLY STABILIZED.
3. SILT FENCE SHALL BE PLACED ON SLOPE CONTOURS TO MAXIMIZE PONDING EFFICIENCY.

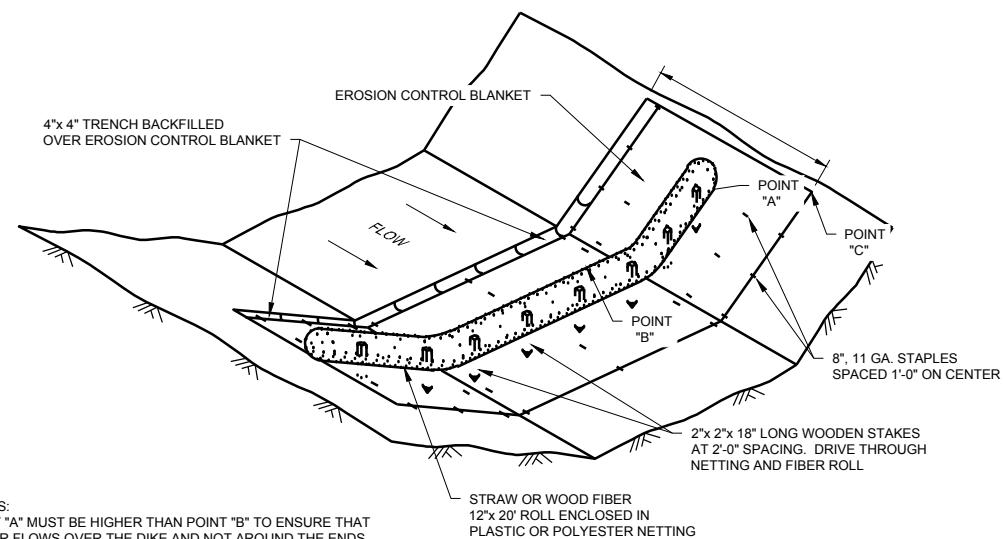

NOTES:

- POINT "A" MUST BE HIGHER THAN POINT "B" TO ENSURE THAT WATER FLOWS OVER THE DIKE AND NOT AROUND THE ENDS. POINT "C" SHALL EXTEND UP SLOPE A MINIMUM 2-FT VERTICALLY TO CONTROL EROSION AROUND END OF STRAW OR WOOD FIBER ROLL.

BIOROLL BLANKET
NOT TO SCALE

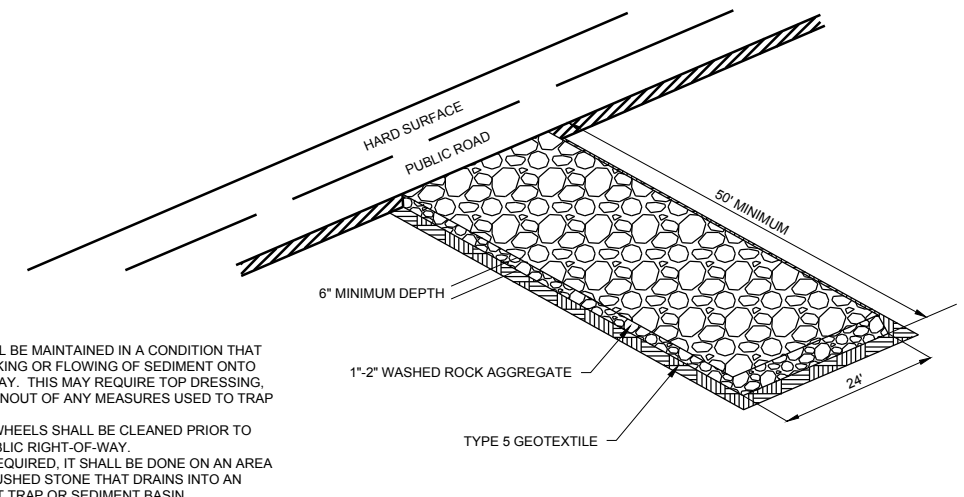

NOTES:

1. THE ENTRANCE SHALL BE MAINTAINED IN A CONDITION THAT WILL PREVENT TRACKING OR FLOWING OF SEDIMENT ONTO PUBLIC RIGHTS-OF-WAY. THIS MAY REQUIRE TOP DRESSING, REPAIR AND/OR CLEANOUT OF ANY MEASURES USED TO TRAP SEDIMENT.
2. WHEN NECESSARY, WHEELS SHALL BE CLEANED PRIOR TO ENTRANCE ONTO PUBLIC RIGHT-OF-WAY.
3. WHEN WASHING IS REQUIRED, IT SHALL BE DONE ON AN AREA STABILIZED WITH CRUSHED STONE THAT DRAINS INTO AN APPROVED SEDIMENT TRAP OR SEDIMENT BASIN.

TEMPORARY ROCK OR WOOD CHIP

CONSTRUCTION ENTRANCE
NOT TO SCALE

H:\Fargo\JBN\6000\6019\15_6019_071\CAD\plans\Erosion Control.dwg SHEET 3-8/6/2015 3:43 PM (araud)

No.	Revision	Date	By

This document was originally signed by Jeffrey T. Lansink, License No. 44790, on 8/06/2015 and the original document is stored at Houston Engineering Inc.



Fargo

P: 701.237.5065
F: 701.237.5101

Drawn by
AMR

Checked by
JTL

Date
8/6/15

Scale
AS SHOWN

STONEMILL ESTATES
2ND ADDITION
MOORHEAD, MINNESOTA

EROSION CONTROL DETAILS

PROJECT NO. 6019-071

SHEET

6 of 70

